

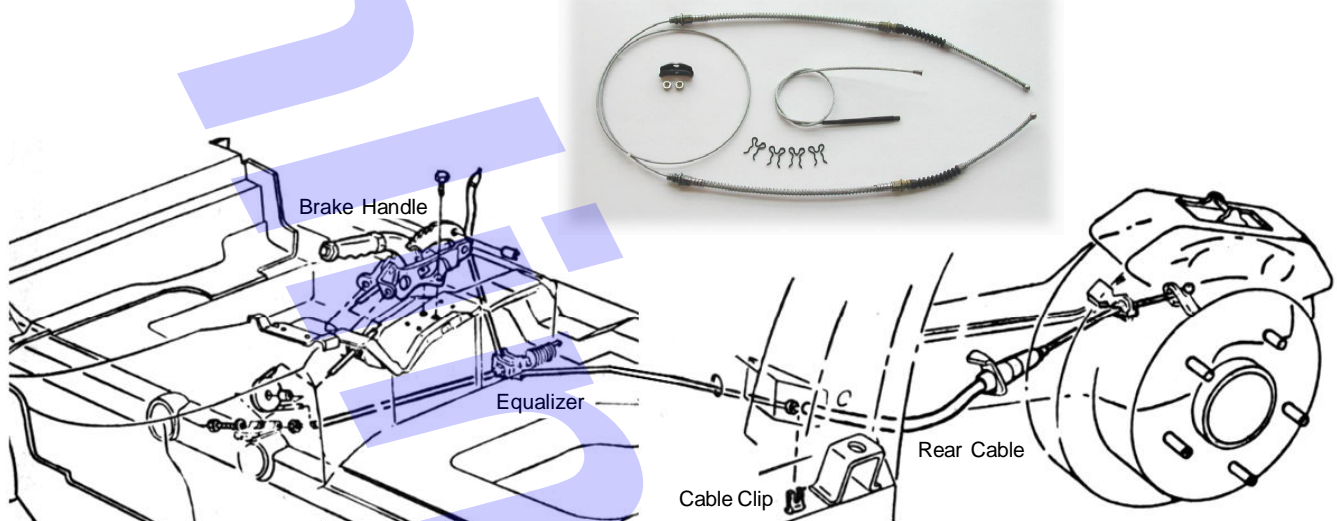

Enclosed Contents: Brake cable set includes: 1 front cable, 1 rear cable, 4 cable clips and 1 equalizer with 2 nuts.



Note 1. Brake cables only need 15 lbs of pressure to start to lock the rear brakes and a max of 30 lbs to fully lock system. There should be enough slack in the system so the brakes do not drag, but also enough tension to fully disengage foot pedal when release handle is pulled. Pedal should return to the full upright position. Foot pedal does not have to be depressed to fully lock system. There is no need to stand on the pedal to fully activate. Warning damage may occur to pedal or cables if excessive force is used.

Step 1. Remove your old cables for comparison. Spring finger 3 prong ends can be removed by taking an 11/16" boxed end wrench and sliding it over the end to depress fingers so cable will slide out. A heater hose clamp will also work the same for removal. Multiple OEM vendors produced the original cables, so detail items such as rubber boots and housing material may vary slightly. Some cables are a flat wind in which a flat metal stock is wound to make the cable. Others are a series of wires held together by one spring wrap. Both cables are correct and function the same, but the appearance is different. We produce cables in the most common material for that particular application. Compare your original cable lengths to the reproductions. It is very common for cable lengths to vary within 1 inch. If your cables vary more than 1 inch, STOP and call Tech Support. We may need your original as an example of what is right for your car.

Step 2. Install all cables and hardware as the above diagram shows. Once all the cables are in place, you are ready to adjust the system. There are several inches of adjustment in the system at the equalizer rod. Snug up the system and read **Note 1** for final adjustment.

Step 3. If you run into problems, your maintenance manual will provide further instructions on cables in section 5 brakes. This sheet is intended for use as a basic guide to help install brake cables. If you are unsure about any part of the installation procedure, consult a professional mechanic. Inline Tube assumes no responsibility for improperly installed cables.